

# QUICK REFERENCE

This Quick Reference contains supply loading information and general care and maintenance procedures for the Monarch® Sierra Sport3™ 9433™ printer. For more detailed information, refer to the *Operator's Handbook* available on our Web site ([www.paxar.com](http://www.paxar.com)).

**Note:** Information in this document supercedes information in previous versions. Check our Web site for the latest documentation and release information.

## Using the Display and Buttons

- Ⓚ Turns the printer on and off. Press and hold for two seconds.
- ⓘ Advances the supply or returns the printer to Ready Mode.
- Ⓜ Selects options on the display.

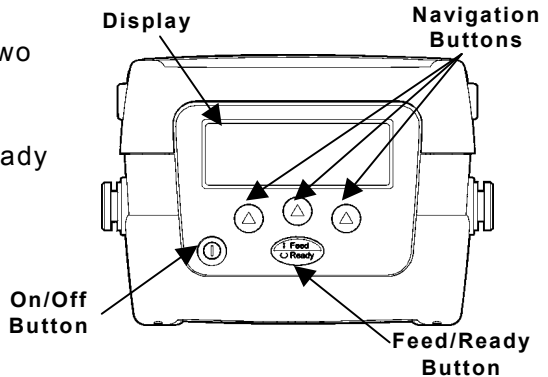



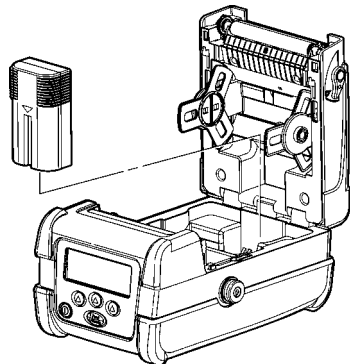
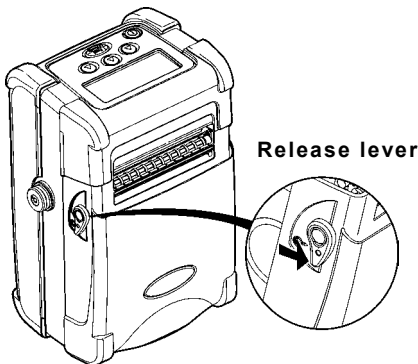

## Using the Battery

You can install the battery with or without supplies loaded.

1. Pull the release levers located on both sides of the printer to open the supply door.
2. Insert the connector end of the battery into the printer.
3. Close the supply door until the release levers click into place.



To check the battery:

The battery status flashes briefly when you turn on the printer. If the printer is already on, press  under . To return to Ready Mode, press  under .

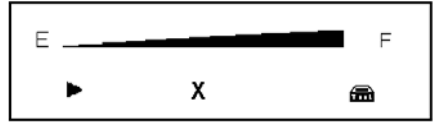

## Sleep Mode

If this option is enabled, the printer goes into sleep mode when it is inactive for a period of time to conserve battery power. The printer displays a coffee cup icon when it is in sleep mode. To wake the printer, press any button except the power button (). Refer to the *System Administrator's Guide* for more information on enabling and disabling sleep mode.

## Connecting the Communications Cable

1. Open the hinged cable door by loosening the Philips screws and lifting up on the door.
2. Plug one end of the cable into the printer port and plug the other end into your computer port.
3. Place the cable in the cable cavity.
4. Close the hinged cable door and tighten the screws.

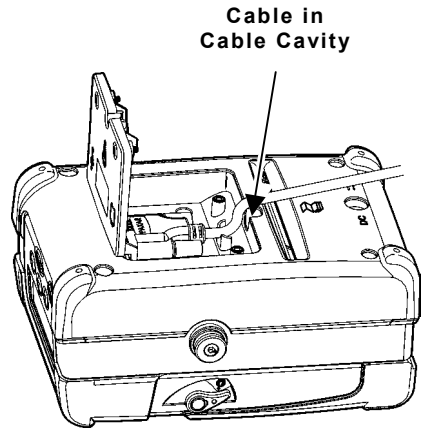
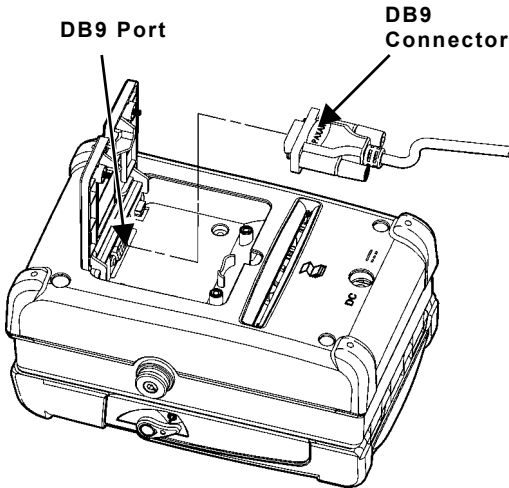

A USB cable is also available. Refer to the *Operator's Handbook* for more information.

# Loading Supplies

1. Pull the release levers located on both sides of the printer to open the supply door.
2. Remove the tape from a new roll of supply.
3. Push apart the supply holder tabs to widen the supply holders. Insert a roll of supplies. Make sure the supply unwinds from the top. Feed the loose end of the supply through the exit chute.
4. Load supply for the print mode you want: Non-Peel or Peel.
5. Press  to advance the supply after loading in all modes. If you receive a supply error, see "Troubleshooting" for more information.

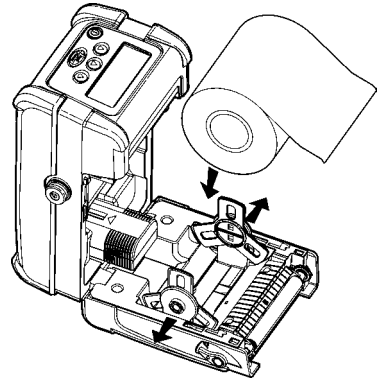

## **For Non-Peel Mode:**

1. Pull out enough supply to lay across the exit chute.
2. Close the supply door until the release levers click into place.

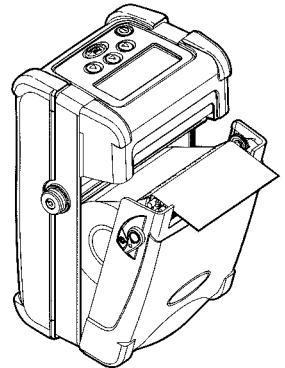

## **For Peel Mode:**

1. Raise the peel tabs on both sides of the printer.
2. Remove a couple of labels from the liner. Feed the liner over the platen roller, over the peel bar, and under the peel roller.
3. Close the supply door until the release levers click into place.

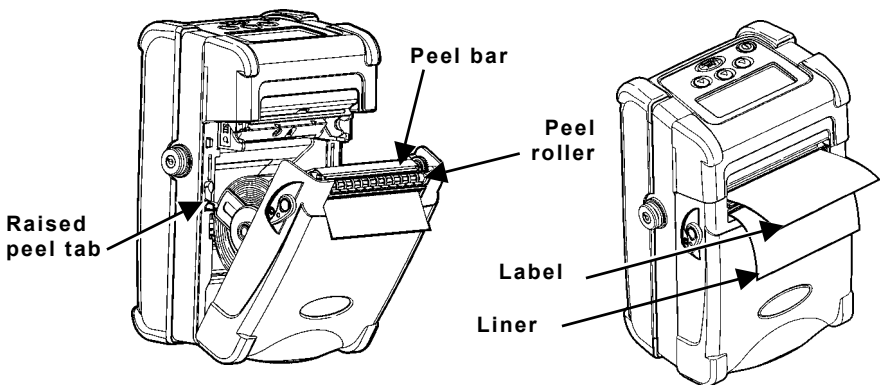

### **For Fan-Fold Supply:**

1. Pull the release levers located on both sides of the printer to open the supply door.
2. Insert the 3" core between the supply holder tabs to open them to their widest position.
3. Place a stack of fan-fold supplies behind the printer, printing side up.
4. Slide the supply guides, located inside the printer on each side of the external supply slot, out to their widest position.
5. Feed the fan-fold supply, printing side up, into the external supply slot on the back of the printer.
6. Adjust the supply guides so that they barely touch the edge of the supply.
7. Pull out enough supply to lay across the exit chute.
8. Close the supply door until the release levers click into place.

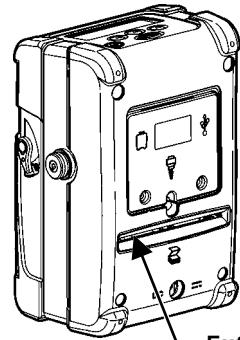

**External  
supply slot**

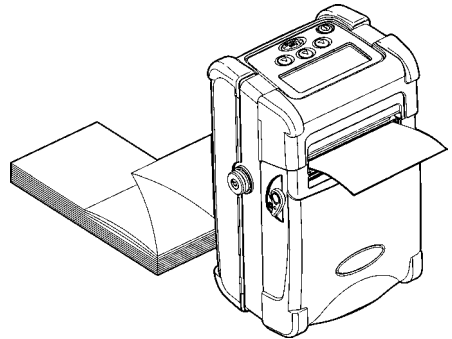

## **Cleaning the Printer**

---

**Do not** use sharp objects to clean the printer. Use isopropyl alcohol on the interior areas only, never on the exterior.

### **Cleaning the Printhead, Platen Roller, and Sensors**

1. Turn off the printer and lay the printer on its back.
2. Open the supply door and remove the supply.
3. Ground yourself by touching a metal surface before cleaning the printer. Grounding prevents electrostatic discharge, which may damage the printer.

4. Clean the printhead with a clean, soft cloth moistened with isopropyl alcohol, a Monarch Cleaning Pen (#114226), or a soft-bristled brush, such as a toothbrush.

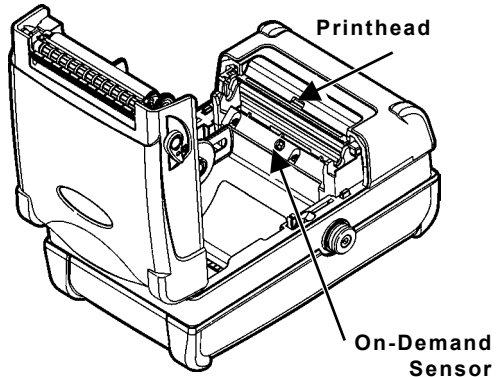

5. Clean the platen roller with a clean, soft cloth moistened with isopropyl alcohol or a cleaning pen.

Turn the platen roller with your finger to make sure it is clean all the way around.

6. Clean the on-demand and black mark sensors with a clean, soft cloth, a cotton swab moistened with isopropyl alcohol, or a cleaning pen.

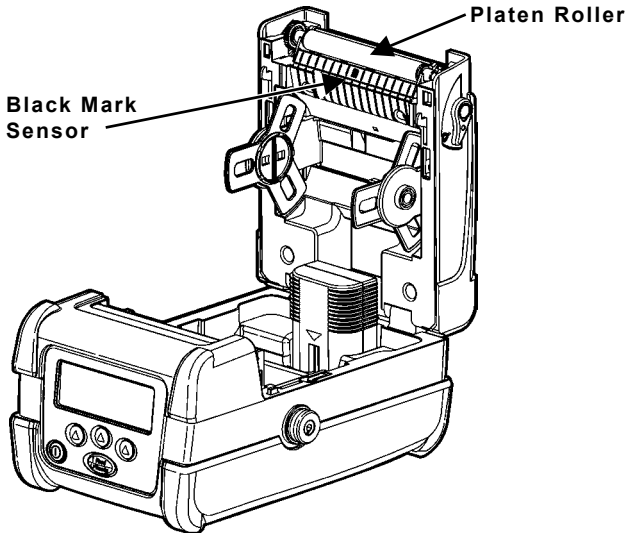

7. Reload supplies and close the supply cover.

## Clearing Label Jams

---

When you are printing and a jam occurs, a supply error message appears on the display. To clear the jam:

1. Turn off the printer and open the supply door.
2. Remove the roll of supplies and jammed labels.
3. Reload the supply.
4. Close the supply door and turn on the printer.

# Troubleshooting

---

To clear an error, press  under **X**.

<b>Problem</b>	<b>Solution</b>
Printer does not feed or print.	Make sure the printer is in Ready Mode.
Print has voids or print is too light.	Load supplies correctly, charge the battery, and clean the printhead.

## Common Errors

---

This section lists some common error messages and their solutions.

<b>Error</b>	<b>Description/Action</b>
411 Framing	Check the cable/Call your System Administrator.
418 Noise	Check the cable/Call your System Administrator.
611 Loading	Font or bar code in the batch does not match the format.
704 – 753 Supply	Check supply tracking, marks, black mark sensor position, and roll for binding. Change supply.

For any other errors, see your System Administrator.

## Configuring the Printer

---

For information on configuring the printer, creating formats, and downloading files, visit our Web site ([www.paxar.com](http://www.paxar.com)).

