

AVERY DENNISON® MONARCH® 9417+ QUICK REFERENCE GUIDE

See our Website, www.rbis.averydennison.com, for more information. Review the *Safety Sheet* provided with your printer.

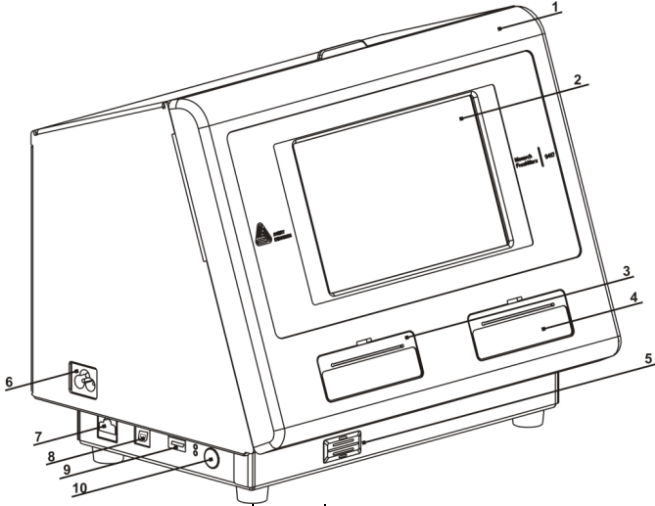

1.	Cover	6.	Power Cord Connection
2.	Display	7.	Ethernet Port
3.	Left Printer	8.	USB (Type B) Port
4.	Right Printer	9.	USB (Type A) Port
5.	Speaker	10.	Power Button

Using the Printer

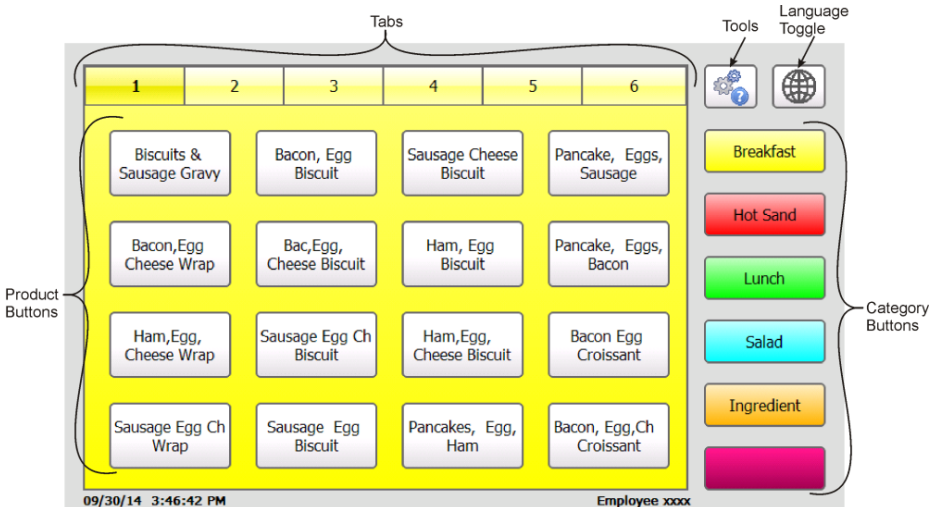

Setting the Time and Date

1. Press the **Tools**  button then select **Admin**.
2. Enter the Admin password and press **Enter**.
The default password is **1234**.
3. Press **Set Time/Date**.

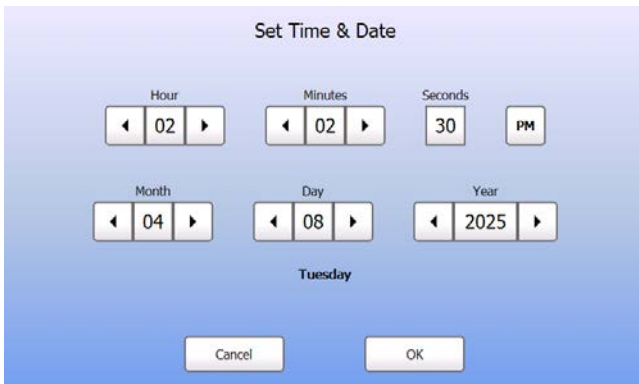

Set Time & Date

Hour: 02 Minutes: 02 Seconds: 30 PM

Month: 04 Day: 08 Year: 2025

Tuesday

Cancel OK

4. Change the time and date as needed then press **OK**.

Printing Labels

1. Turn on the printer.
2. Press the product button of the label to print.
3. Select the number of labels and press **Enter**. To print one label, press **Enter**.
4. Labels print for the selected product.

Note: To print a Use First label, press the Tools button, Use First, then select the number of labels to print.

Loading Labels - Left Printer

1. Turn on the printer then open the cover.
2. Pull on the supply tab.

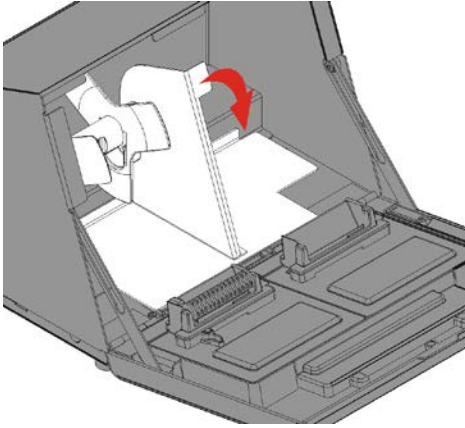

3. Unlock the supply guide and remove it.

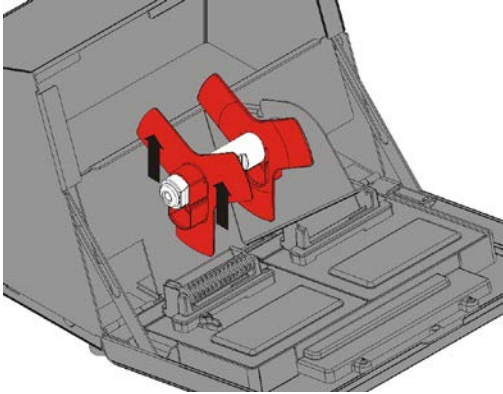

4. Place a roll of labels (label side up) on the supply holder. Place the supply guide on the supply holder.

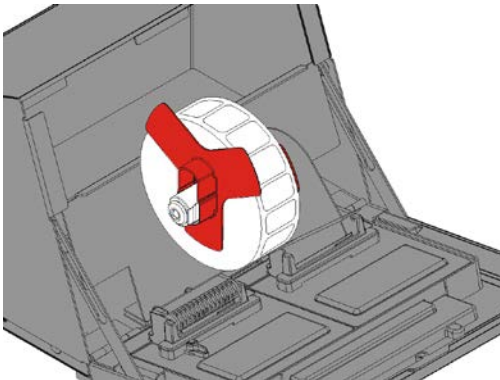

5. Lock the supply guide.

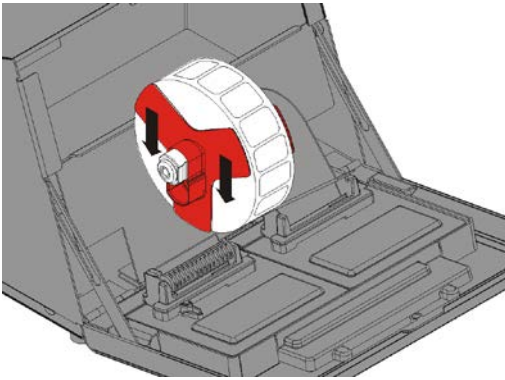

6. Put the supply tab back.

7. Guide the labels along the inside edge and into the slot. The printer feeds the supply.

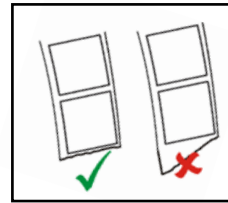
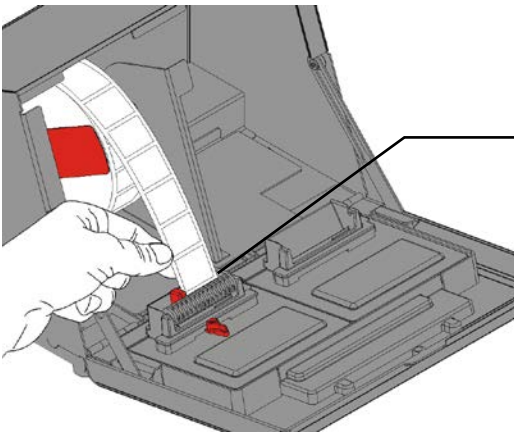

8. Slide the supply lever next to the supply. Close the supply lever.

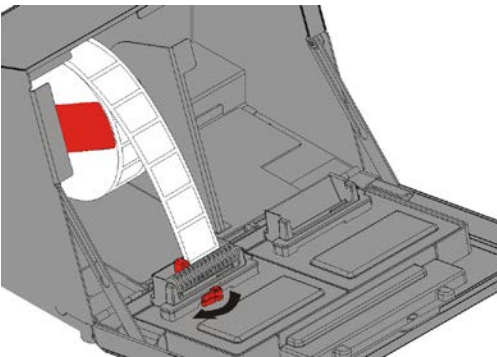

9. Close the cover.

Loading Labels – Right Printer

1. Turn on the printer then open the cover.
2. Pull on the supply tab.
3. Unlock the outer supply guide and remove it.

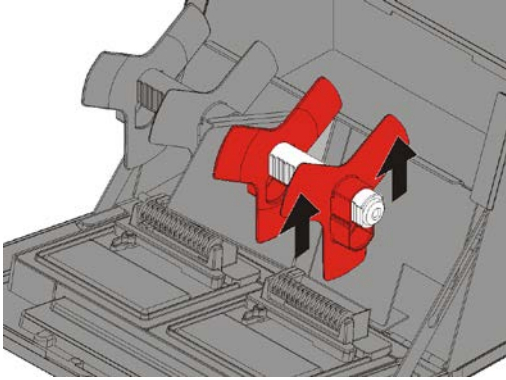

4. Place a roll of labels (label side up) on the supply holder.
5. Replace the outer supply guide and lock it in place.

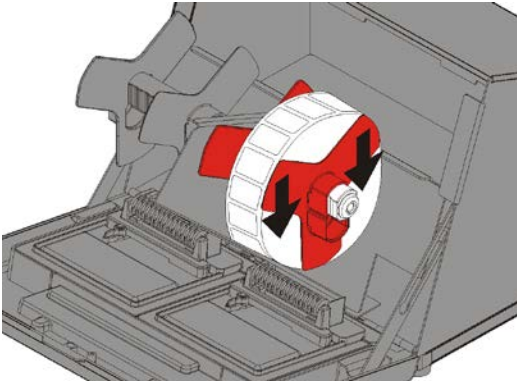

6. Unlock the inner supply guide, move it until it touches the supply, lock it into place.

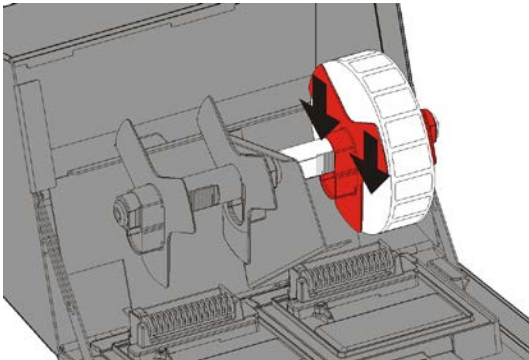

7. Put the supply tab back.
8. Guide the labels along the outside edge and into the slot. The printer feeds the supply.

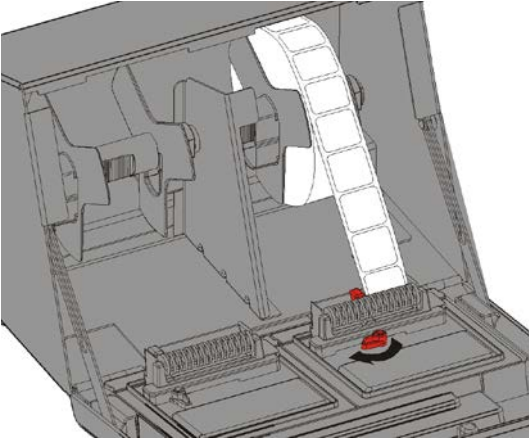

9. Slide the supply lever next to the supply and close it.
10. Close the cover.